

OpenAir™

Air damper actuators

Rotary version, two-position control,
with spring return, AC 24 V or AC 230 V

GCA12...1
GCA32...1

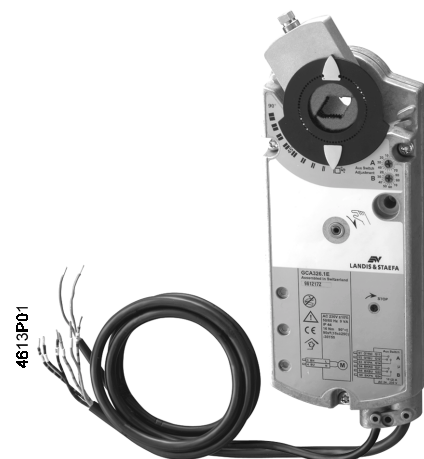

Electromotive rotary actuators for two-position control, nominal torque 16 Nm, spring return to fail-safe position, operating voltage AC 24 V or AC 230 V, for two-position control, span mechanically adjustable between 0...90°, pre-wired with 0.9 m long connection cables.

Type-specific variations with adjustable auxiliary switches for supplementary functions.

Use

To control air dampers in ventilating and air conditioning plants

- using a nominal torque of 16 Nm for damper surfaces up to 3 m², friction-dependent.
- requiring fail-safe position (zero position) when there is a power failure.

Functions

Basic functions

Rotational movement

- Direction of rotation (right or left) determined by the actuator's mounting on the damper shaft.
- As soon as an operating voltage of either AC 24 V or AC 230 V is applied, the actuator turns to "90°".

Fail-safe function

In the event of power failure or when the operating voltage is shut off, the actuator spring returns to the fail-safe position "0" .

Position indication

The position indicator located on the shaft adapter displays the rotational angle position of the damper blade.

Manual override

The actuator can be turned to any position using a hex wrench and locked using a screwdriver. After mechanically releasing the lock or after briefly applying operating voltage, the actuator returns to the "0" position.

Mechanical limitation of rotational angle

The rotational angle of the shaft adapter can be limited to 5° increments between 0° and 90°.

Type-specific functions

Adjustable auxiliary switches

Auxiliary switches provide supplementary functions. The switching points for switches A and B (one changeover switch each) can be set independently in increments of 5° within the 0°...90° rotational angle.

Refer to "Technical design", "Commissioning notes" and "Internal diagram".

Summary of types

Operating voltage			
AC 24 V		AC 230 V	
Standard application	With 2 auxiliary switches	Standard application	With 2 auxiliary switches
GCA121.1E	GCA126.1E	GCA321.1E	GCA326.1E

Ordering

The auxiliary switches **cannot** be integrated retroactively. For that reason, order the respective type that contains the desired option.

Delivery

Due to various mounting options depending on the direction of rotation and shaft length, separate parts such as the shaft adapter with position indicator and other mounting parts are shipped separately with the actuator.

Connection cables

The actuator comes with 0.9 m long pre-wired connection cables.

Accessories and spare parts

The following accessories and spare parts are available for function upgrades of the actuators; see data sheet N4699:

Accessories

- Rotary/linear set for duct mounting **ASK71.1**
- Rotary/linear set for wall mounting **ASK71.2**
- Rotary/linear set with lever **ASK71.3**
- Rotary/linear set with lever and mounting plate **ASK71.4**
- Bracket for Powerpack **ASK73.1**
- Weather shield **ASK75.1**

Spare parts and ordering information as per data sheet

N4699

Equipment combination

These actuators can be connected to all regulating and controlling devices with a two-position output supplying a switching voltage of AC 24 V or AC 230 V.

Technical design

Motor technology

The brushless DC motor provides accurate speed control, torque monitoring to protect the actuator and dampers as well as a reliable fail-safe function.

Spring return mechanism in the event of power failure

Springs supply the fail-safe function. The problems caused by conventional frictional grip for multi-stage gearing are solved using a second, synchronously turning spring in the motor which eliminates the motor's frictional grip.

Adjustable auxiliary switch
(type-specific)

The illustration below shows the adjustable switching values for auxiliary switches A and B in relation to the rotational angle.

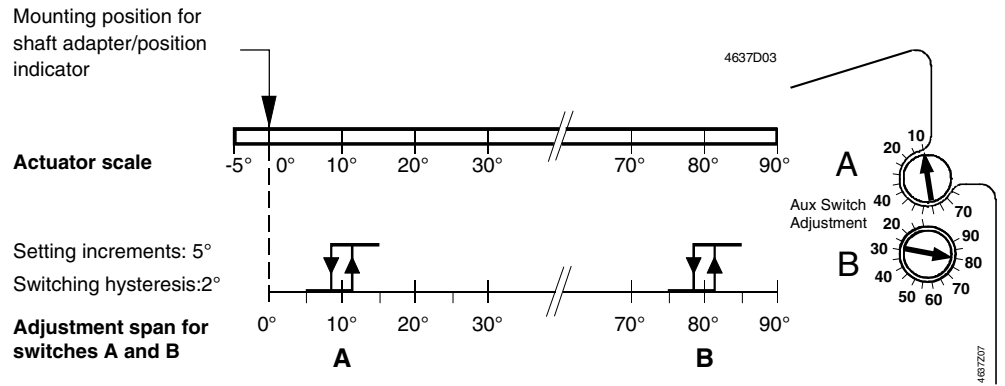

Note

The setting shafts for the auxiliary switches turn together with the actuator. The scales are valid only for the zero position of the actuator.

Mechanical design

Basic components

Housing	Robust, lightweight all metal housing made from aluminum diecast which guarantees a long actuator life even under extreme ambient conditions.
Gear train	Maintenance-free and noise-free gear train with stall and overload protection for the life of the actuator.
Spring preload	The spring has a factory set preload of 5° which ensures tight close-off for the air dampers.
Manual adjustment	A wrench lock in the center of the actuator allows the manual setting of the gears. A hex wrench is supplied.
Self-centering shaft adapter	The actuator can be fastened to shafts with various diameters and in various shapes (square, round) using just one screw due to the L&G patented mounting. Insert the shaft adapter from either side into the opening for the shaft adapter depending on the damper shaft length. For short shafts, the shaft adapter is on the duct side. The shaft adapter coupling and the shaft holding are coupled via double-sided gearing.
Mechanical limitation of the rotational angle	The limitation of the rotational angle can be adjusted in the span of 0...90° in increments of 5°.
Mounting bracket	A metal strip with bolt serves to fasten the actuator on the opposite side of the shaft holding.
Electrical connection	All actuators come with pre-wired 0.9 m long connection cables.
Note	You can mount the actuator on either side depending on the required rotation direction. All setting and operating elements are available on both sides of the actuator.

Type-specific elements

Auxiliary switches	For supplementary functions, the auxiliary switches A and B can be adjusted on the actuator front, below the opening for the shaft adapter.
--------------------	---

Setting and operating elements

Refer to "Technical design" and "Commissioning notes" in this data sheet.

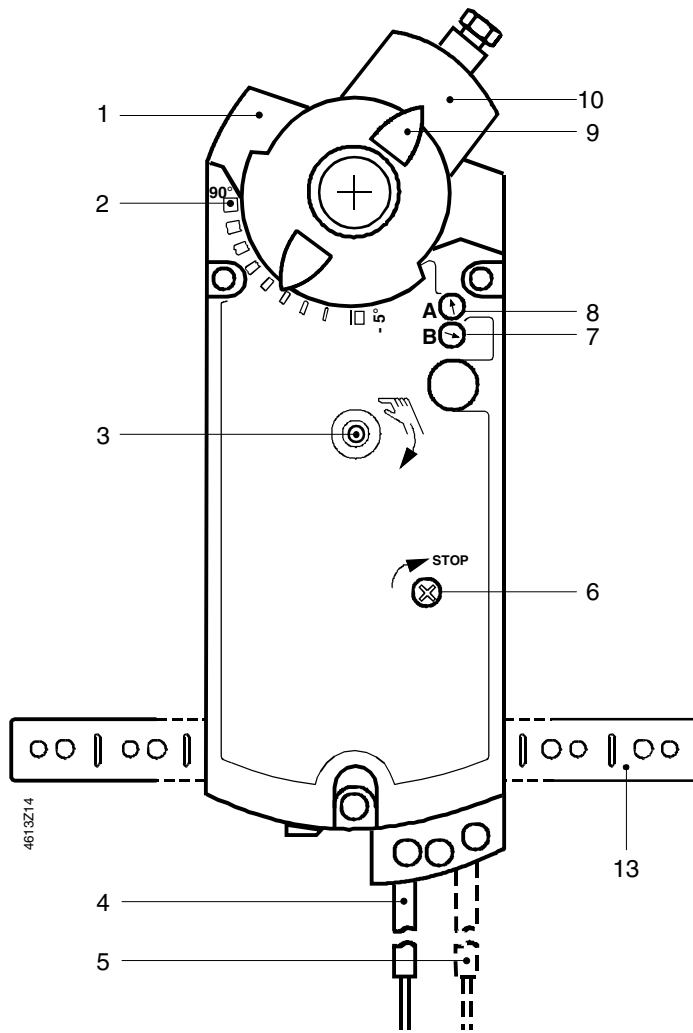

- 1 Housing
- 2 Angle of rotation scale 0°...90°
- 3 Wrench lock for manual override
- 4 Connection cable for power supply
- 5 Connection cable for auxiliary switches
- 6 Stop shaft for gear train
- 7, 8 Adjustment dials for auxiliary switches A and B
- 9 Position indicator
- 10 Self-centering shaft adapter
- 11 Locking ring for shaft adapter
- 12 Adapter for position indicator
- 13 Mounting bracket

Arrangement for long shaft adapters

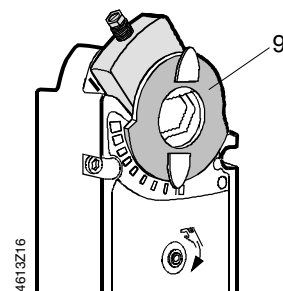
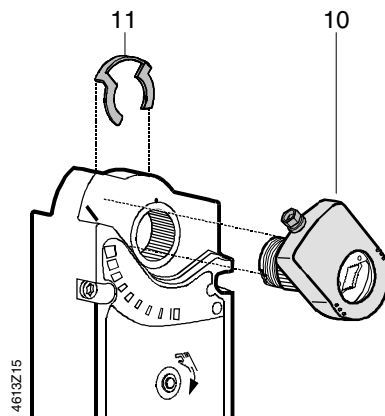

Arrangement for short shaft adapters

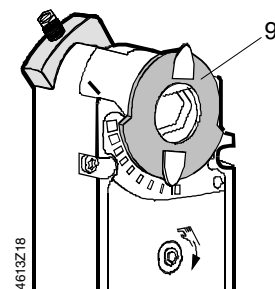
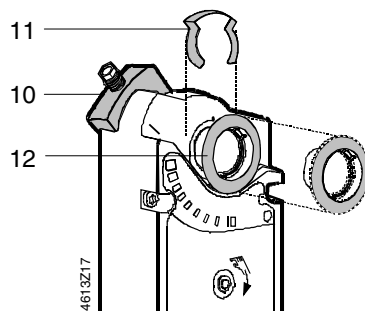

Engineering notes



The basic system data for the control systems in use contains all engineering notes. Read all the engineering notes before mounting, wiring, and commissioning the actuator and pay special attention to all safety information.

Proper use

These actuators must be used in a system only for applications as described in the basic system data documents for the applied control systems. Additionally, all actuator specific features and rules must be observed as described in the brief description on the title page of this data sheet (bold print) and in the chapters "Use", "Engineering notes", and "Technical data".



All paragraphs marked with the special warning triangle as illustrated on the left contain additional safety information and limitations that must be observed under any circumstances to avoid physical injuries or damages to equipment.

 AC 24 V supply

These actuators must only be used with **safety extra-low voltage (SELV)** or **protection by extra-low voltage (PELV)** in accordance with HD 384.

 AC 230 V supply

The actuators are double-insulated and do not provide a connection for the protective ground.

 Auxiliary switches A,B

Use **either line voltage or safety extra-low voltage** for auxiliary switches A and B. Do not mix the two for operation. However, operation using various phases is permissible.



Warning, maintenance

Do not open the actuator!

The actuator is maintenance-free. Maintenance work may only be conducted by the manufacturer.

Parallel connection of actuators

- **Electric:** Electric parallel connection for the same actuator types is permissible provided the operating voltage is within the required tolerance. Voltage drops at the feed lines must be included.
- **Mechanical:** On using the bracket for Powerpack ASK73.1, the actuators may be mounted on the same damper shaft.

Required actuators

The quantity of actuators required depends on several torque factors. After obtaining the damper torque rating (Nm/m^2) from the manufacturer and determining the damper area, calculate the torque required to move the damper as follows:

Total Torque = Torque Rating \times Damper Area

Calculating the required actuators

$$\text{Number of actuators} = \frac{\text{Total Damper Torque required}}{\text{SF}^1 \times \text{Actuator Torque (Refer to Specifications)}}$$

¹ Safety Factor: When calculating the number of actuators required, a safety factor should be included for unaccountable variables such as slight misalignments, aging of the damper, etc. A suggested safety factor is 0.80 (or 80% of the rated torque).

Sizing transformers for AC 24 V

- Use safety insulating transformers with double insulation in accordance with EN 60 742; The transformers must be made for 100% runtime.
- Observe all local safety rules and regulations pertaining to sizing and protecting transformers.
- Determine the transformer's power consumption by adding the power consumption in VA for all actuators used.

Wiring and commissioning

Refer to "Commissioning notes" and "Internal diagram" in this data sheet as well as to the HVAC job drawings.

Mounting notes

Mounting instructions	All information and steps to properly prepare and mount the actuator are listed in the Mounting Instruction guide M4613 delivered with the actuator. The shaft adapter as well as all other individual parts are not pre-mounted as the actuator components are put together differently depending on the direction of rotation (right or left) and the damper shaft length. Refer to "Mechanical design" in this data sheet.
Mounting position	Select the mounting position so that you can easily access the cables as well as the setting dials on the front of the actuator. Refer to "Dimensions".
Housing protection	In order to satisfy the requirements as per IP54, the following mounting conditions must be fulfilled: <ul style="list-style-type: none">• Mount the actuators only vertically (cabling see below) for air dampers with horizontal shafts.• When the actuator is mounted directly on the damper shaft, the mounting angle may be a maximum of $\pm 45^\circ$.• Use the ASK75.1 weather shield for mounting in any other position.
Mounting bracket	If you mount the actuator directly on the damper shaft, the mounting bracket must be used. The insertion depth for the shaft into the housing must be sufficient and guaranteed.
Damper shafts	Information on minimum length and diameter for the damper shaft is listed in "Technical data".
Spring preload	The actuator is shipped with a 5° preload which ensures closing pressure for the air dampers.
Mechanical limitation of the rotational angle	If necessary, you can limit the rotational angle in increments of 5° for the entire span by positioning the shaft adapter in the respective position.
Using the mounting sets	The mounting sets which are used to change the rotational movement into a linear stroke as described in "Type summary" are mounted separately.

Commissioning notes

References	All information necessary for commissioning is contained in the following: <ul style="list-style-type: none">• This data sheet 4613• Mounting instructions M4613• Job diagram
Environmental conditions	Check to ensure that all permissible values as contained in "Technical data" are observed.
Mechanical check	<ul style="list-style-type: none">• Check for proper mounting and to ensure that all mechanical settings are in accordance with the plant-specific requirements. Additionally, ensure that the dampers are shut tight when in the closed position.• Fasten the actuator securely to avoid side load.• Check the rotation direction: Manually change the damper position by turning the gearing using a plug-in hex wrench in accordance with the mounting instructions.
Electrical check	<ul style="list-style-type: none">• Check to ensure that the cables are connected in accordance with the plant wiring diagram.• The operating voltage AC 24 V (SELV/PELV) or AC 230 V must be within the tolerance values.• Functional check:<ul style="list-style-type: none">– The actuator must turn from 0° to 90° (end position with rotational angle limitation) when applying operating voltage.– After interrupting the supply voltage, the actuator must return to the zero-position.• Switch the auxiliary switch contacts "A" and "B" while the actuator reaches the respective switching positions.

Factory settings for auxiliary switches A and B (see "Technical design")

The auxiliary switches are factory set:
 Switch A: Switching point at 5°
 Switch B: Switching point at 85°

To change the settings of A and B, use a flat blade screwdriver to turn the switch adjustment dials to the desired setting.

Important

The angle values are valid only for the actuator position "0°". (The switch adjustment dials turn together with the actuator).

Technical data

⚠ Power supply AC 24V for
 GCA121.1E
 GCA126.1E

Operating voltage	AC 24 V ± 20 %
Safety extra-low voltage (SELV) or protection by extra-low voltage (PELV) as per	HD 384
Protection class	III as per EN 60 730
Requirements for external safety insulating transformer (100% duty) to	EN 60 742
Feeder protection external	max. 10 A
Frequency	50/60 Hz
Power consumption: running	8 VA/6 W
holding	3 VA/1.5 W

⚠ Power supply AC 230V for
 GCA321.1E
 GCA326.1E

Operating voltage	AC 230 V ± 10 %
Protection class	II as per EN 60 730
Feeder protection extern	max. 10 A
Frequency	50/60 Hz
Power consumption: running	9 VA/6 W
holding	9 VA/2.3 W

⚠ Auxiliary switches for
 GCA126.1E
 GCA326.1E

Contact rating	6 A resistive, 2 A inductive
Life: 6 A resistive, 2 A inductive	10 ⁴ switchings
5 A resistive, 1 A inductive	5 x 10 ⁴ switchings
no load	10 ⁶ switchings
Voltage	AC 24...230 V
Protection class	II as per EN 60 730
Voltage proof auxiliary switch to housing	AC 4 kV
Setting range for switchover contacts	5°...85°
Setting increments	5°
Switching hysteresis	2°
Factory setting:	
Switch A	5°
Switch B	85°

Connection cables

Power supply line AC 24 V (wires 1-2) / AC 230 V (wires 3-4)	2 x 0.75 mm ²
Auxiliary switch cables (wires S1...S6)	6 x 0.75 mm ²

Mechanical data

Nominal torque	16 Nm
Restoring torque (for power failure)	16 Nm
Min. holding torque	> 16 Nm
Max. torque	< 50 Nm
Nominal angle of rotation (with position indication)	90°
Max. angle of rotation (mechanically limited)	95° ± 2°
Runtime for nominal angle of rotation 90° (motor operation)	90 s
Closing (on power loss) with spring return	15 s
Direction of rotation (determined by type of mounting)	clockwise/counter clockwise
Mechanical life	10 ⁵ cycles
Dimensions for the damper shaft	
Round	8...25.6 mm
Square	6...18 mm
Min. length	20 MONOGR
Max. shaft hardness	< 400 HV
Actuator dimensions	see "Dimensions"
Weight	
GCA121.1E, GCA126.1E	2 kg
GCA321.1E, GCA326.1E	2.1 kg

Environmental conditions

Transport	IEC 721-3-2
Climatic conditions	Class 2K2
Temperature	-32...+70 °C
Humidity (non-condensing)	< 95% r.h.
Mechanical conditions	Class 2M3

Operation	IEC 721-3-3
Climatic conditions	Class 3K5
Mounting location	Inside, weather -protected
Temperature	-32....+55 °C
Humidity (non-condensing)	< 95% r.h.
IP-Code	Housing type according to EN 60 529
	IP 54
CE Conformity	In accordance with the directives set forth by the European Union
	Electromagnetic compatibility (EMC)
	Low voltage directive
	89/336/EEC
	73/23/EEC
Product standards	Automatic electric regulating and controlling devices for residential use and other applications (Type 1)
	EN 60 730-2-14
Electromagnetic compatibility	Emissions
	Immunity
	EN 50 081-1
	EN 50 082-2

Diagrams

Internal diagrams

GCA121.1E
GCA126.1E

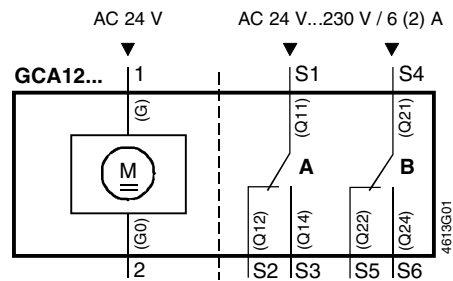

AC 24 V (SELV/PELV)

GCA321.1E
GCA326.1E

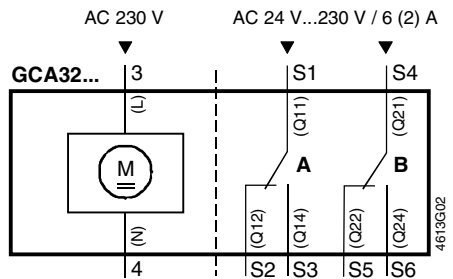

AC 230 V

Cable labeling

All wires are color-coded and labeled.

Connection cable	Wire labeling	Designation	Color	L&G terminal code
Actuators AC 24 V	1	System potential AC 24 V	red	G
	2	System neutral	black	G0
Actuators AC 230V	3	Phase AC 230 V	brown	L
	4	Neutral conductor	blue	N
Auxiliary switches	S1	Switch A Input	gray/red	Q11
	S2	Switch A Normally closed contact	gray/blue	Q12
	S3	Switch A Normally open contact	gray/pink	Q14
	S4	Switch B Input	black/red	Q21
	S5	Switch B Normally closed contact	black/blue	Q22
	S6	Switch B Normally open contact	black/pink	Q24

Connection diagram

GCA121.1E
GCA126.1E

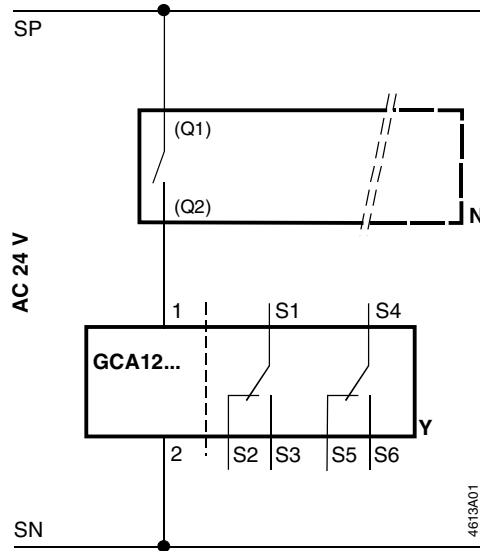

AC 24 V (SELV/PELV)

- N Regulator or controller
- Y Actuator GCA12..., two-position, AC 24 V
- SP System potential AC 24 V
- SN System neutral

GCA321.1E
GCA326.1E

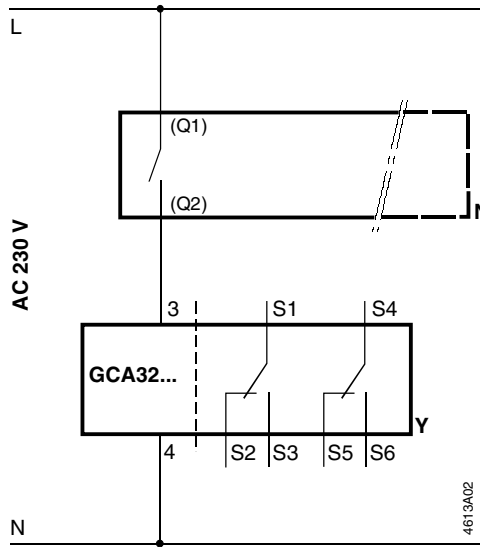

AC 230 V

- N Regulator or controller
- Y Actuator GCA32..., two-position, AC 24 V
- L Phase conductor AC 230 V
- N Neutral conductor

Dimensions

